

# REB70-花键轮毂型

REB70-Spline Wheel Type

## 技术参数

## Technical Data

机座号 Base No.	静扭矩 Static Torque (N.m)	线圈参数(20℃时)Coil(20℃)				耐热等级 Heat Resistance	最高转速 Max. Rotation Speed (r/min)	转子转动惯量 Moment of Inertia of Rotator J(kg.m <sup>2</sup> )	容许制动功率 Allowable Braking Power Eba (J)	总制动做功 Total Brake Power Output (J)	吸引时间 Engaging Time (ms)	释放时间 Releasing Time (ms)	背隙 [°] Gap	质量 Weight (kg)
		电压 Voltage (V)	功率 Power (W)	电流 Current (A)	电阻 Resistance (Ω)									
40	0.35	24	6.3	0.26	91.43	F	6000	3.7X10 <sup>-7</sup>	18	3600	40	20	0.5	0.14
60	1.5	24	7.2	0.30	80.00	F	6000	2.4X10 <sup>-6</sup>	104	20800	50	20	0.5	0.3
80	3.2	24	8.5	0.35	67.76	F	6000	8.6X10 <sup>-6</sup>	240	48000	60	20	0.5	0.5
110	10	24	17.7	0.74	32.54	F	5000	3.7X10 <sup>-5</sup>	500	1X10 <sup>5</sup>	100	40	0.5	1
130	16	24	23	0.96	25.04	F	5000	1.6X10 <sup>-4</sup>	1000	2X10 <sup>5</sup>	110	40	0.5	1.5
180	45	24	24	1.00	24.00	F	3600	4.5X10 <sup>-4</sup>	1500	3X10 <sup>5</sup>	120	60	0.5	3.6

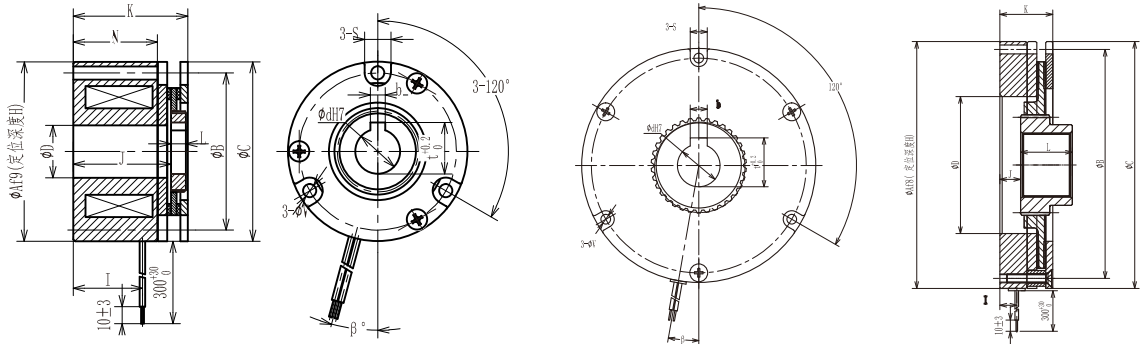

机座号 Base No.	径向尺寸/Radial Dimension [mm]								轴向尺寸/Axial Dimension [mm]							轴径/Axial Radius [mm]			
	A	B	C	D	E	S	V	H	I	J	K	W	N	β	L	d	b	t	d Max
40	35	29.5	35	9	\	6.5	3.4	4	6.5	22	26	AWG26	19	-30	4	8.5	3	9.3	8.5
60	48	42	48	14	\	8	3.4	4	18.5	26.1	30.5	AWG22	22.5	0	4	12	4	13.8	15
80	64	57	64	22	\	8	3.4	4	17.5	25.5	30.3	AWG22	21.5	-30	4	17	5	19.3	20
110	84	74	84	32	\	10	4.5	4	9.5	27.5	34.5	AWG22	22	15	30	20	7	23	25
130	115	104	115	65	\	10	4.5	4	14.8	18	28	AWG22	18.8	0	30	25	8	28.3	30
180	150	135	150	55	\	12	6.5	4	13.5	26.2	36	AWG22	18.5	30	30	30	8	33.3	40